



SURVEYING & MAPPING
Certificate of Authorization No. LB7264
Prepared by: Jeff S. Hodapp, P.S.M.
947 Clint Moore Road
Boca Raton, Florida 33487
Tel: (561) 241-9988
Fax: (561) 241-5182

HEATHWOOD RESERVE P.U.D.
A REPLAT OF ALL OF TRACT 10 AND A PORTION OF TRACTS 9 AND 16 OF THE NORTHWEST 1/4 OF SECTION 36, TOWNSHIP 44 SOUTH, RANGE 42 EAST, "PLAT OF SEC. 36 - T44S, R42E.", ACCORDING TO THE PLAT THEREOF RECORDED IN PLAT BOOK 3, PAGE 10, OF THE PUBLIC RECORDS OF PALM BEACH COUNTY, FLORIDA, IN SECTION 36, TOWNSHIP 44 SOUTH, RANGE 42 EAST, PALM BEACH COUNTY, FLORIDA.

155

NOTES:
COORDINATES, BEARINGS AND DISTANCES

COORDINATES SHOWN ARE GRID
DATUM - NAD 83 1990 ADJUSTMENT
ZONE - FLORIDA EAST
LINEAR UNIT - US SURVEY FOOT
COORDINATE SYSTEM 1983 STATE PLANE
TRANSVERSE MERCATOR PROJECTION
ALL DISTANCES ARE GROUND, UNLESS OTHERWISE NOTED
SCALE FACTOR = 1.000037
GROUND DISTANCE X SCALE FACTOR = GRID DISTANCE
BEARINGS AS SHOWN HEREON ARE GRID DATUM,
NAD 83 1990 ADJUSTMENT, FLORIDA EAST ZONE

LEGEND:

- SET P.R.M. (UNLESS OTHERWISE NOTED) 4" x 4" CONC. MON. WITH ALUMINUM DISK STAMPED LB7264 CENTERLINE PERMANENT CONTROL POINT L.B. 7264

ABBREVIATIONS:

- CONC. COR. CONCRETE CORNER
D. DELTA (CENTRAL ANGLE)
D.E. DRAINAGE EASEMENT
P.D.E. PUBLIC DRAINAGE EASEMENT
F.P.L. FLORIDA POWER AND LIGHT COMPANY LICENSED BUSINESS
L.B.E. LANDSCAPE BUFFER EASEMENT
L.M.E. LAKE MAINTENANCE EASEMENT
L.M.A.E. LAKE MAINTENANCE ACCESS EASEMENT
L.S. LICENSED SURVEYOR
L.S.E. LIFT STATION EASEMENT
L.W.D.D. LAKE WORTH DRAINAGE DISTRICT MONUMENT
O.R.B. OFFICIAL RECORDS BOOK
P.B. PLAT BOOK
R. RADIAL
L. ARCLENGTH
N.R. NON-RADIAL
RAD. RADIAL
P.B.C.R. PALM BEACH COUNTY RECORDS
P.B.C.U.E. PALM BEACH COUNTY UTILITY EASEMENT
PG. PAGE
P.G.S. PAGES
P.O.B. POINT OF BEGINNING
P.O.C. POINT OF COMMENCEMENT
P.R.M. PERMANENT REFERENCE MONUMENT
P.S.M. PROFESSIONAL SURVEYOR & MAPPER
P.U.D. PLANNED UNIT DEVELOPMENT
R.A.S. RESIDENTIAL ACCESS STREET
R.L.S. REGISTERED LAND SURVEYOR
R/W. RIGHT-OF-WAY
SEC. SECTION
U.E. UTILITY EASEMENT
PC. POINT OF CURVATURE
PT. POINT OF TANGENCY
P.C. POINT OF COMPOUND CURVATURE
NT. NON-TANGENT
D.B. DEED BOOK
M.R.O.E. MAINTENANCE AND ROOF OVERHANG EASEMENT
P.C.P. PERMANENT CONTROL POINT
P.D.E. PUBLIC DRAINAGE EASEMENT

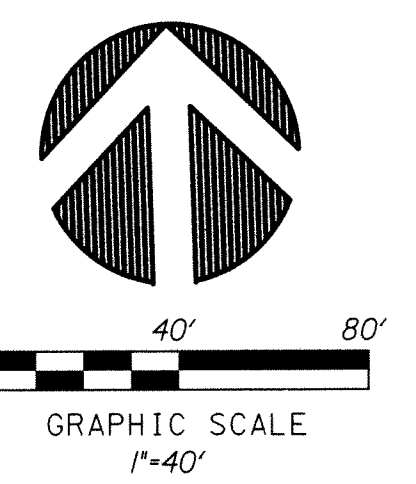
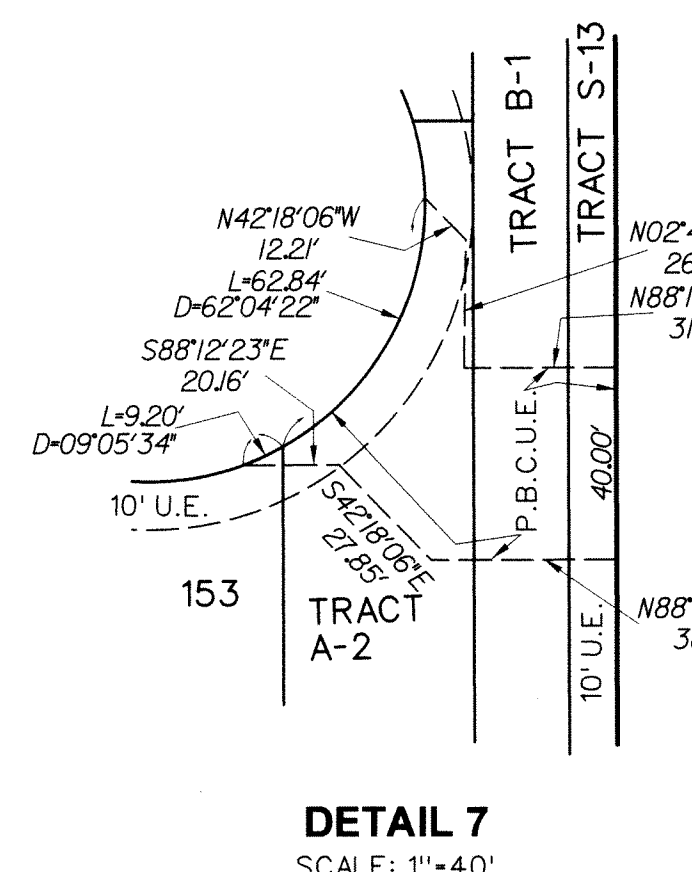
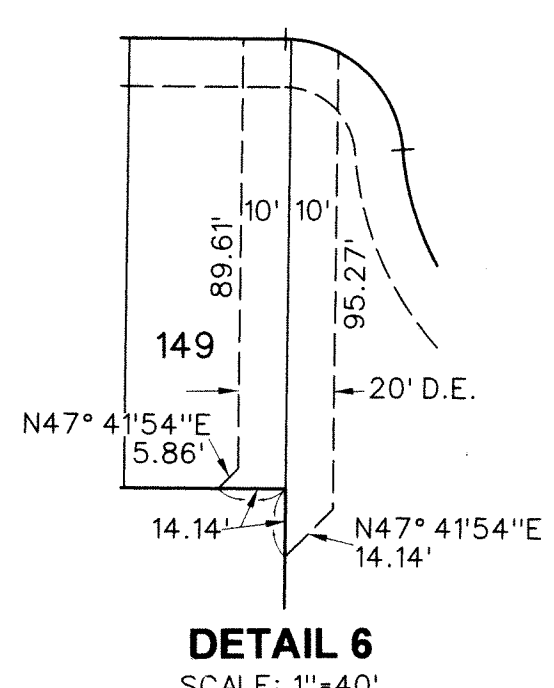
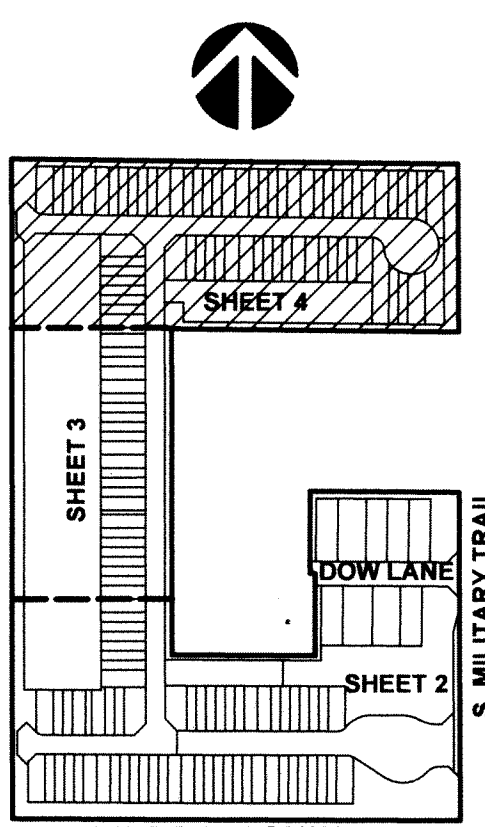

P.O.C. FOUND PBC BRASS DISK NE COR NW 1/4 SECTION 36-44-42 (CALCULATED POSITION) N 826118.226 E 945652.902 FOUND PBC BRASS DISK "L 14 ML" N 826073.471 E 945651.686

SHEET 4 OF 4

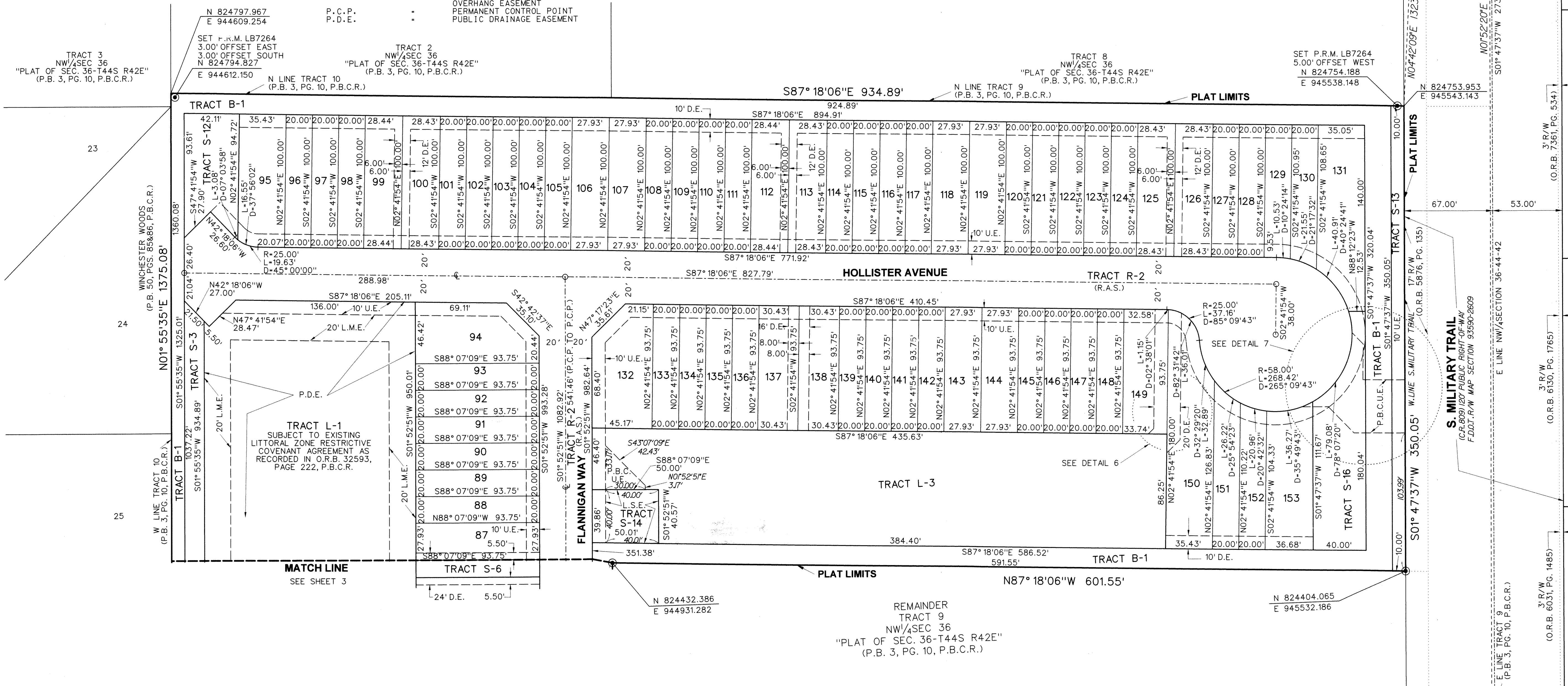

7

6

7